



WORLD'S SMALLEST REFLECTIVE LED CONTROLLER

SAFETY RULES

- Do not connect the device to loads exceeding the permitted values.
- Connect only in accordance with the diagram presented in the manual. Improper connections may be dangerous, it can damage the controller, and loss of the warranty.
- DANGER! Risk of electric shock! Even with the device turned off, the outputs may be live. All assembly work should be ALWAYS performed with the disconnected power circuit.
- Connecting the device to a power supply that does not meet the quality requirements specified in EN 50081-1, EN 50082-1, UL508, EN 60950 will invalidate the warranty.

CONNECTION DIAGRAM

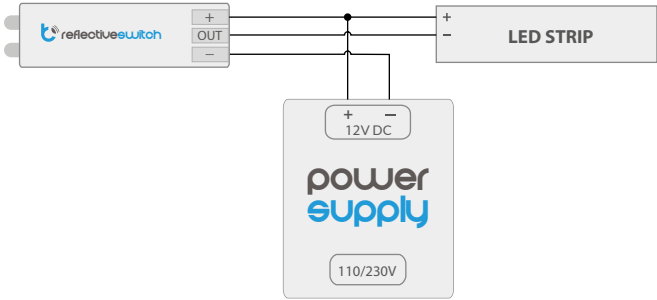

Attention! When soldering the wires be careful not to overheat the controller board.

1 INSTALLATION

- Before installing the controller, disconnect the voltage in the supplied circuit. Remember that all assembly work should be carried out with the power supply disconnected.
- The controller should be mounted in a place protected from adverse environmental conditions, protected from access by third parties - in the LED profile or in the interior of the transparent housing of the controlled device. It is advisable that the device is mounted in a stable and stationary position.
- Familiarize yourself with the diagram and then proceed with the assembly of the controller. Pay special attention to the designation of the controller connectors. Start by connecting the power wires: (+) (red or black with a white dotted line) and (-) (black).
- Connect (paying attention to polarity) the LED strip. The device is equipped with a strip of adhesive tape on the underside. Before sticking the controller, clean and dry the surface to which it will stick. Remove the protective film, glue it in the chosen place and hold for a few seconds. When choosing a mounting location, remember that the sensor in the front of the device should be placed at a distance of 3-20 mm from the detected element (eg cabinet door or drawer wall).

If the moving surface is dark, it is advisable to stick a piece of white sticker on it to improve the detection range of the controller.

- Connect the device to the power supply and check that the device correctly detects the movable element.

2 MODE SETTINGS

- The controller can work in three different modes:
 - The default, as a mono-stable switch**, which switches off the LED strip when an object is detected. This mode is useful, for example, in a cabinet that turns on the light when the door opens
 - Mono-stable**, switching on the LED strip when an object is detected, e.g. mounted in a door frame, switching on the lighting only when the sliding door is fully separated
 - Bi-stable**, applicable, for example, as a proximity switch, allowing you to turn on / off the light using your hand, eg under the mirror, behind the photo frame

3 CHANGE OF MODE

- To change the work mode, perform the following steps:
 - Unplug the power supply for 10 seconds and then connect it again.
 - Approach and remove your finger from the sensor (the connected LED lighting will blink, it means the status will change). Repeat the action 10 times in a maximum of 15 seconds being connected to the supply source.

10x / 15 sec.

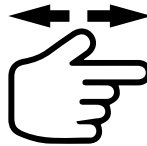

The 5 times fast blinking of the connected LED lighting informs that the programming mode has been entered correctly:



the controller will inform about the selected mode through the blinking sequence (starts from 1): Mode 1 - sequence of 1 blink, Mode 2 - sequence of 2 blinks, Mode 3 - sequence of 3 blinks

- To change the mode, approach and remove your finger when the LED lighting connected to the controller is off.

1x



the controller will inform about the selected mode through the blinking sequence (starts from 1): Mode 1 - sequence of 1 blink, Mode 2 - sequence of 2 blinks, Mode 3 - sequence of 3 blinks

After the blinking sequence is repeated three times, the controller will select that mode.

5 times the fast blinking of the connected LED lighting, informs that it has successfully left the programming mode:



TECHNICAL SPECIFICATIONS

supply voltage	12-24V DC
energy consumption	< 0,1W
maximum current	5A
maximum power	60-120 W
sensor	optical, reflective
mounting method	in LED profile / heat-shrink tubing
connection method	soldering, screw terminal
dimensions	34 x 10 x 3 mm
protection level	IP00
controller operating temperature	from -20 to + 50°C
mode	NO, NC, bistable

for more information visit our website

www.blebox.eu

or send us an email to: info@blebox.eu

support is available at support@blebox.eu

made in Europe



proudly made by

blebox

